

CALIFORNIA AIR TOOLS 60050SCR Ultra Quiet & Oil-Free Continuous Run

(100% Duty Cycle) Scroll 5.0 Hp 60 Gallon
ASME Tank Air Compressor



5.0 Hp
(Running/Rated)

60 Gallon Steel Air Tank

13.0 CFM @ 40, 60 & 90 PSI

208-220 Volts / 60 Hertz / Single Phase

CONTINUOUS RUNNING up to 10 hours at 90 PSI and 12 hours at 40 PSI

The CALIFORNIA AIR TOOLS 60050SCR Ultra Quiet & Oil-Free Continuous (100% Duty Cycle) 5.0 Hp Air Compressor is designed to be one of the quietest air compressors in the industry having only 77 decibels of sound.



SCROLL **5 HP Oil-Free Continuous Run Motor-Pump**

77 Decibels

Pressure Control Gauge Condor Pressure Switch

60 Gallon Steel ASME Air Tank **325lbs 208/230 Volts 23 Amps**

1/2" NPT Female Port

ASME Certification

Ball Drain Valve

ULTRA QUIET

OIL-FREE

ONLY 77 DB NOISE LEVEL

The Powerful 5.0 hp scroll air compressor operates at 77 decibel noise level.

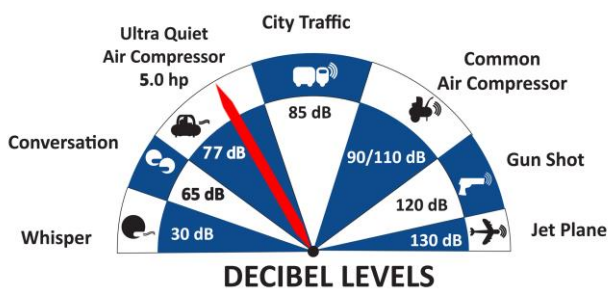

The Powerful 5.0 hp scroll air compressor operates at only 1700 RPM creating less noise and less wear.

CONTINUOUS RUNNING up to 10 hours at 90 PSI and 12 hours at 40 PSI or below.

The Oil-Free Scroll System is engineered for high performance and durability.

The CAT-60050SCR Air Compressor has a Oil-Free Scroll System that is designed to have a life cycle before maintenance/service of 5,000 hours of usage.

The large 60 gallon steel air tank is just the right size for a shop, warehouse or factory.

Designed for people looking for Oil-Free Continuous Air Flow with at Least 30% Less Noise!

FEATURES

- * **Ultra Quiet** - Only 77 decibels
- * Oil-Free Scroll - Cleaner air for better tool operation.
Less maintenance and Costs.
- * Pressure control gauge
- * 1/2" NPT Female Port (pressure regulator not included)
Optional Pressure Regulator available for purchase ([click here](#))
- * Condor Pressure Switch
- * Thermal Overload Protector
- * Maximum Pressure - 100 PSI @ 208v & 115 PSI @ 230v
- * 208 Volt (200v-216v), 230 Volt (220v-240v) / 60 Hertz / Single Phase
- * Amp Draw - 23 amps @ 208v & 22 amps @ 230v
- * Power Requirements: Dedicated 30 amp outlet
- * Plug Type: NEMA L6-30P Receptacle: NEMA L6-30R
- * Maximum Operating (ambient) Temperatures: 36 to 104°F
- * Time to fill tank from empty to full - 4 min 28 seconds
- * Recovery time from 85 PSI to 115 PSI - 1 min 8 seconds
- * 60 Gal. Steel Air Tank
- * L (30") x W/D (25") x H (83")
- * 325 lbs
- * Commercial Use: Refer to State & City Codes
- * ASME Certified Air Tank
- * 1 Year Limited Warranty
- * Assembled in USA with global components

Power Switch and Tank Gauge:



Manual Drain Valve:



60050SCR Air Pump Drawing:

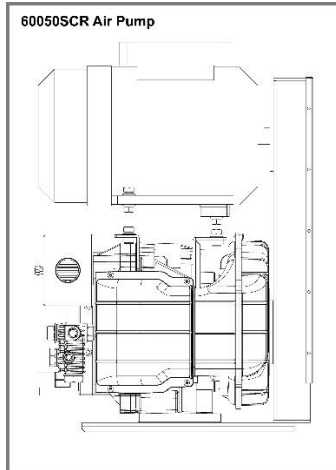

60 Gallon Tank Dimensions:

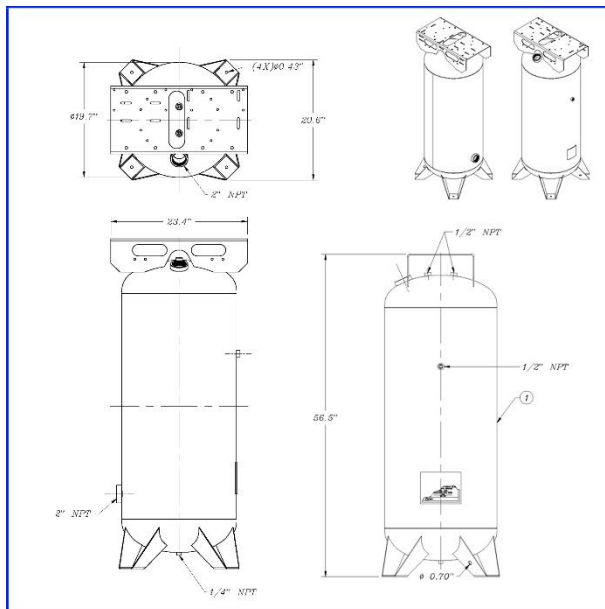

For more information, please visit California Air Tools:

<https://www.californiaairtools.com/industrial-series-of-quiet-compressors-industrial-grade/cat-60050scr/>

Manufactured in Mexico & USA using global components.

MODEL: 60050SCR

PART NUMBER: CAT-60050SCR

www.californiaairtools.com

Revision A: 05-2024