

CALIFORNIA AIR TOOLS 60065C Powerful 6.5 Hp Ultra Quiet & Oil-Free 60 Gallon ASME Air Compressor



6.5 HP (Rated/Running)

60 ASME Gallon Steel Tank

20.0 CFM @ 40 PSI

17.0 CFM @ 90 PSI (480 liters per minute)

**230V 3-Phase 60hz
15Amp**

The CALIFORNIA AIR TOOLS 60065C Ultra Quiet & Oil-Free Air Compressor is designed to be one of the quietest 6.5 Hp air compressors in the industry having only 85 decibels of sound.





The powerful 6.5 HP motor operates at only 3400 RPM creating up to 20 CFM air flow and is designed to increase duty cycle and allow for longer continuous run operations.



ULTRA QUIET

ONLY 85 DB NOISE LEVEL

The Oil-Free Quad Piston Pump System is engineered for high performance and durability.

Designed for the person looking for Power, Oil-Free Air Flow and at Least 30% Less Noise!



ASME CERTIFIED TANK

The large 60 Gallon ASME Steel Air Tank is just the right size to support a large facility including commercial business, manufacturing operations, autobody shops and other general pneumatics that require air volumes of up to 20 cfm.

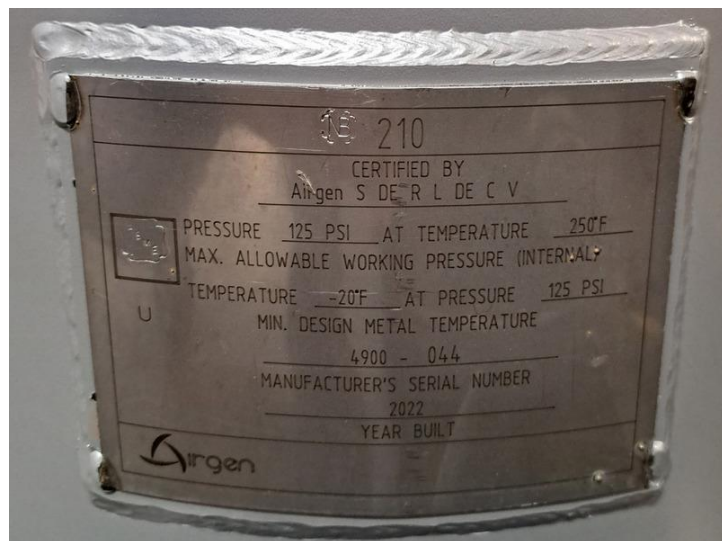

FEATURES

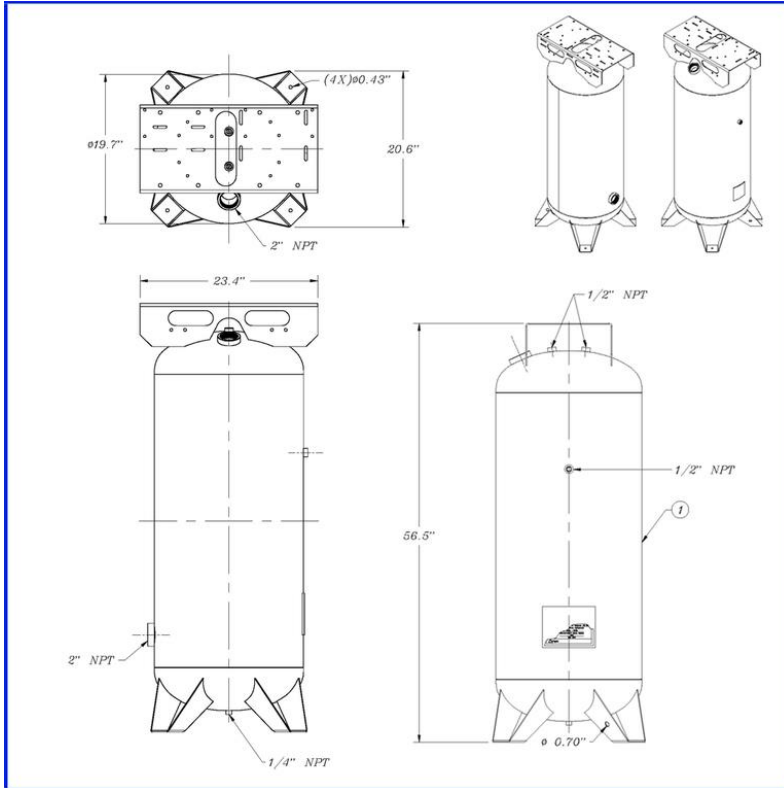

L15-20R Electrical Receptacle (3-phase, 20 ampere, 220 volts)

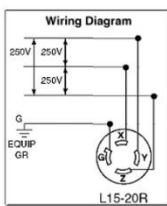

L15-20P Plug



- * **Ultra Quiet - 85 decibels**
- * Oil-Free Pump - Cleaner air for better tool operation.
Less maintenance and Costs.
- * One tank pressure gauge
- * 1/2" NPT female port
No output pressure regulator, quick connector or air hose included
- * Condor Pressure Switch
- * Thermal Overload Protector
- * 120 PSI Maximum Pressure
- * 230 Volt / 60 Hertz / 3-Phase (range 215v to 240v)
- * Amp Draw - 15 Amps
- * 20 Amp Breaker suggested
- * Time to fill tank from empty to full - 191 Seconds
- * Recovery time from 92 PSI to 120 PSI - 35 Seconds
- * Less heat which dissipates more efficiently
- * 60 Gallon ASME Steel 155 PSI Air Tank
- * L (32.5") x W (28") x H (60.5")
- * 260 lbs
- * Manual Drain Valve with Strainer cleanout
- * Comes complete with (4) Air Filters
- * Plug Type: Nema L15-20P (connect to L15-20R receptacle)
- * Cord Length: 7ft
- * 70/30 Duty Cycle Rating*
- * Commercial Use: Refer to State & City Codes
- * 1 Year Limited Warranty
- * Assembled in Mexico & USA with Global Components

For more information and to watch a 60065C product demonstration please visit California Air Tools:
<https://www.californiaairtools.com/contractor-grade-ultra-quiet-series-of-air-compressors/6-0-hp-air-compressor/cat-60065c/>

Manufactured in Mexico using global components.

MODEL: 6065C

PART NUMBER: CAT-6065C

www.californiaairtools.com

Revision A: 06-2024