



**CALIFORNIA AIR TOOLS 60040DCAD Powerful 4.0 Hp Ultra Quiet & Oil-Free Air Compressor with 80% Air Drying System and Automatic Drain Valve**



**60** Gallon

**4** HP Motor

**125** PSI MAX

**10.6** CFM @90PSI

**75** Decibels

**80%** Dry Air

**4.0 HP**  
(Rated/Running)

**60 Gallon ASME Certified Steel Air Tank with Automatic Drain Valve**

**80% Air Drying System**

**12.80 CFM @ 40 PSI**

**10.60 CFM @ 90 PSI**

**220 Volts / 60 Hertz / Single Phase**

The CALIFORNIA AIR TOOLS 60040DCAD Ultra Quiet & Oil-Free Air Compressor with Air Drying System is designed to be one of the quietest 4.0 Hp air compressors in the industry having only 75 decibels of sound.



**75 Decibels**

**4 Hp Oil-Free Dual-Piston Long-Life Motor Pump**

Tank Pressure Gauge

Air Dryer System

**60 Gallon Steel Air Tank with Air Dryer and Auto Drain**

Output Pressure Regulator

Regulated Pressure Gauge

5 Micron Air Filter

**248 lbs 220 Volts 14 Amps**

Automatic Drain Valve



The Powerful Twin 2.0 HP (SP-9421-22060) motors operate at only 1680 RPM creating less noise and less wear.

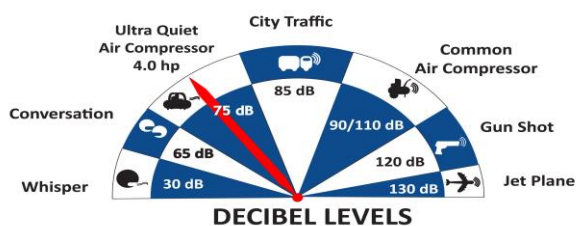

ULTRA QUIET

ONLY 75 DB NOISE LEVEL

The Oil-Free Dual Piston Pump System is engineered for high performance and durability.

The CAT-60040DCAD Air Compressor has a Oil-Free Dual Piston pump designed to have a life cycle before wear of 3000 Plus hours.

The Oil-Free pump allows for use in a variety of temperatures (cold starts) and uneven terrains (no oil in the pump).

The large 60 Gallon Steel ASME Air Tank is just the right size for a shop or garage.

## 80% AIR DRYER SYSTEM

The 80% Air Dryer is specially designed to remove water vapor from the air to protect sensitive tools and machinery.

To dry the air from the air compressor an Aftercooler and 80% Air Dryer are utilized.

The aftercooler is a heat exchanger for cooling the discharge air from the air compressor. The water vapor from the compressed air is condensed into liquid form and pushed into the Air Dryer.

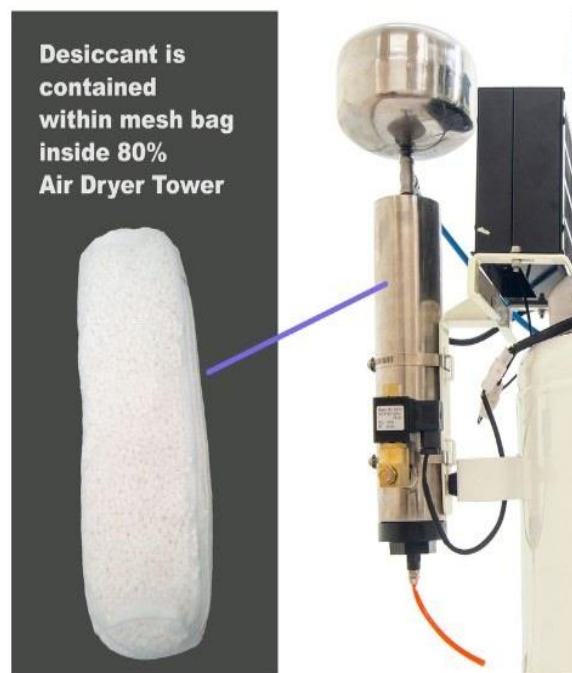

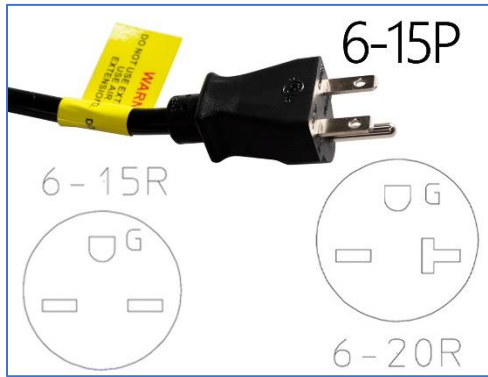
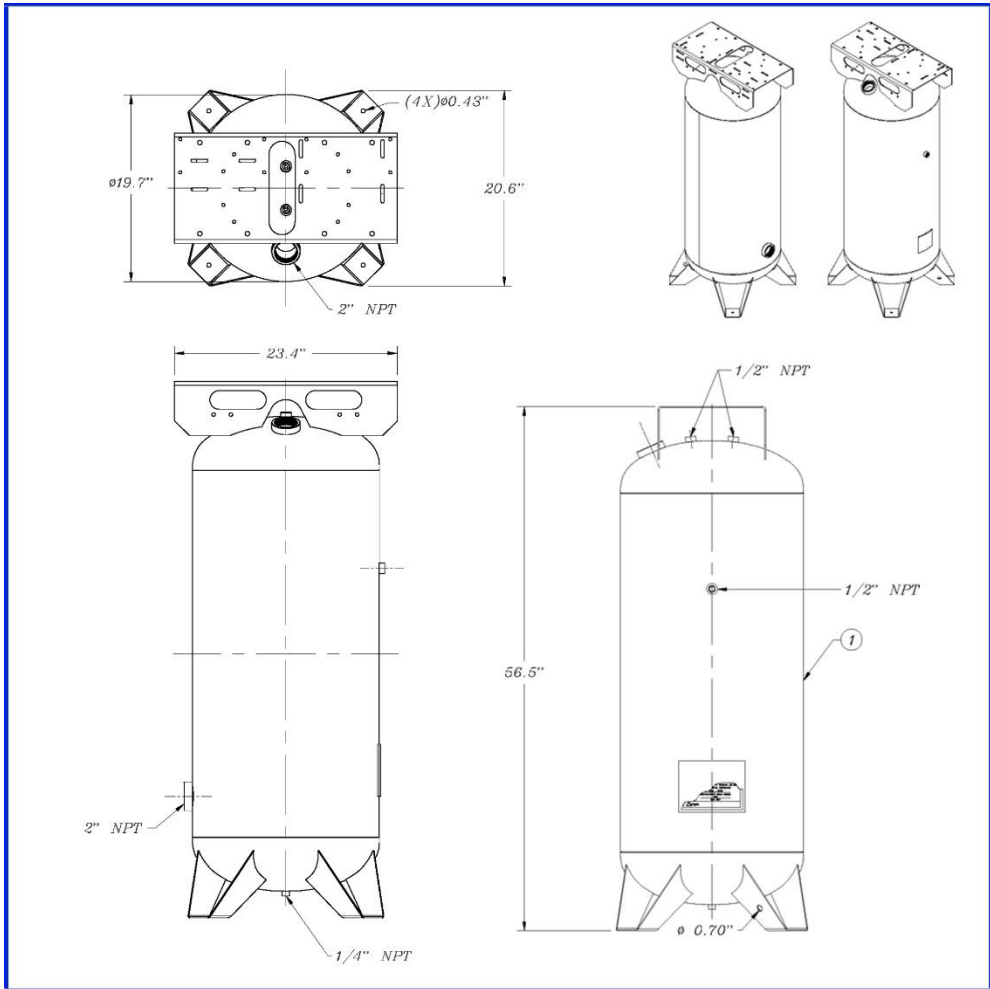

## FEATURES

- \* **Ultra Quiet** - Only 75 decibels
- \* Oil-Free Pump - Cleaner air for better tool operation.  
Less maintenance and Costs.
- \* Two pressure control gauges
- \* 5 Micron Air Filter & Regulator with a 3/8" Port
- \* Air Hose Port 3/8"
- \* Condor Pressure Switch
- \* Thermal Overload Protector
- \* 125 PSI Maximum Pressure
- \* 220 Volts / 60 Hertz / Single Phase - (No 208 Volts - if necessary, obtain 208 to 220 voltage booster)
- \* Low Amp Draw - 14 Amps
- \* Time to fill tank from empty to full - 6:30 Minutes
- \* Recovery time from 95 PSI to 125 PSI - 2:00 Minutes
- \* Duty Cycle - 70/30\*
- \* Less heat which dissipates more efficiently.
- \* 60 Gal. Steel ASME Air Tank
- \* L (25.5") x W/D (29") x H (66.5")
- \* 248 lbs
- \* Air Dryer - Includes Activated Alumina desiccant with a 4000-hour life.  
Activated Alumina is used in air prepurification (due to its high water and carbon dioxide adsorption capacity) and adsorption of sulphur compounds.
- \* Aftercooler (condenser)
- \* EZ-1-2321 Auto Drain Valve Factory Installed
- \* Comes complete (4) Air Filters
- \* Plug Type: Nema 6-15P (fits Nema 6-15R or 6-20R receptacle)
- \* ASME Certified for Commercial Use
- \* 1 Year Limited Warranty
- \* Commercial Use: Refer to State & City Codes
- \* Assembled in USA with global components

For more information and to watch a 60040DCAD product demonstration please visit California Air Tools: <https://www.californiaairtools.com/air-dryer-ultra-quiet-oil-free-air-compressors/cat-60040dcad/>

*Manufactured in Mexico using global components.*

*MODEL: 60040DCAD*

*PART NUMBER: CAT-60040DCAD*

*[www.californiaairtools.com](http://www.californiaairtools.com)*

*Revision A: 07-2024*